

# SPECTRA CLEAN™ SERIES MODEL - WILDCAT E 1.5

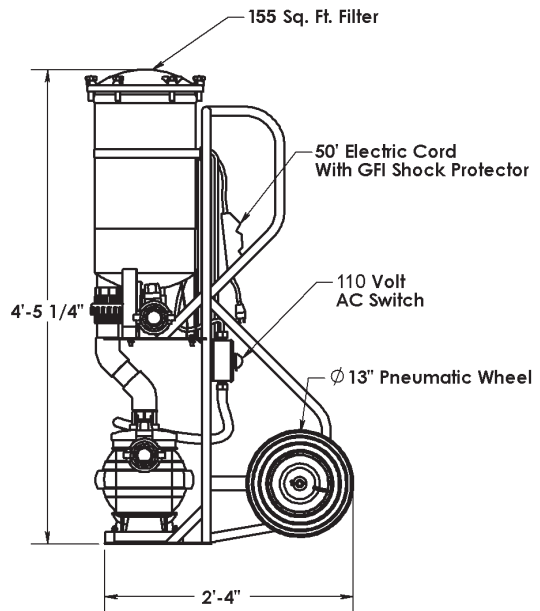
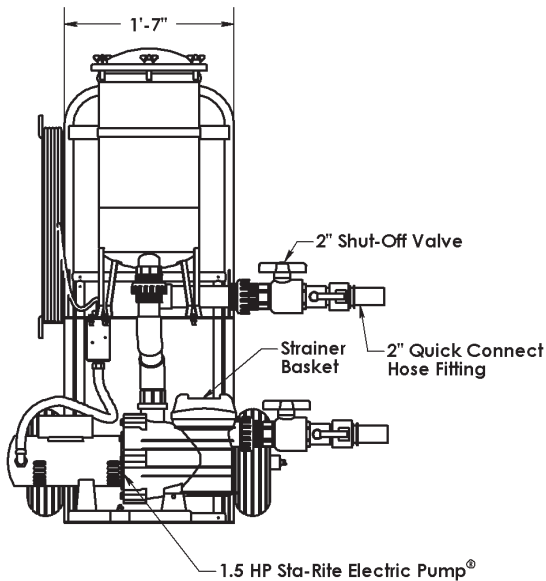
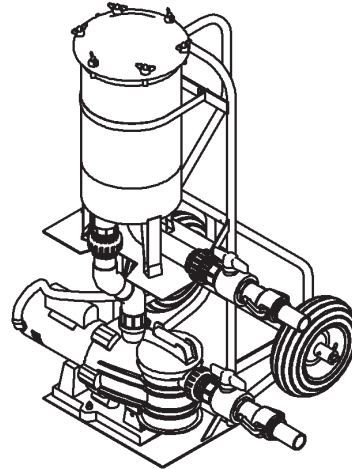
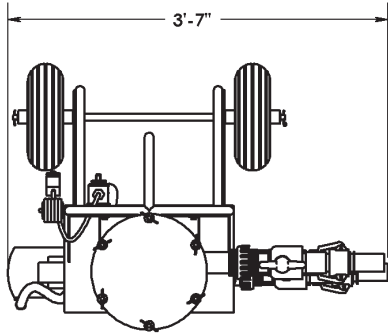

- APPROVED
- REVISE AND RESUBMIT
- APPROVED AS CORRECTED
- REJECTED
- SUBMIT SPECIFIED ITEM

Approval is only for conformance with the design concept of the Project and compliance with the information given in the Contract Documents. Contractor is responsible for dimensions to be confirmed and correlated at the job site for information that pertains solely to the fabrication process or to techniques of construction, and for coordination of the work of all trades.

Signature \_\_\_\_\_ Date \_\_\_\_\_

*\*Note: Drawings not to scale. Specifications are nominal and are subject to change.*



7100 Spectrum Lane  
Missoula, Montana 59808  
406.542.9781 • 800.791.8056  
Fax: 406.542.1158  
www.spectrumproducts.com

## ENGINEERING DATA

|               |               |
|---------------|---------------|
| Product:      | Wildcat E 1.5 |
| Product #:    | 10600         |
| Date:         | 11/2006       |
| Data Sheet #: | SA 10600.1106 |

## **Spectra Clean Series, Wildcat E 1.5, part number 10600-00**

The portable filtration system shall consist of the following components:

### **Cart**

The portable filtration system cart shall be constructed of 1.25" x .065" wall thickness stainless steel. All metallic components shall be passivated for maximum corrosion resistance. The cart shall be fitted with two (2) 13" pneumatic wheels.

### **Filter**

A stainless steel filter canister shall be provided with the portable filtration system. It shall be designed to receive a 155 square foot single cartridge filter and shall have a removable lid.

### **Pump**

A 1.5 horsepower Sta-Rite® Dyna-Max pump shall be provided. It shall pre-plumbed to the filter canister and mechanically fastened to the cart. It shall be pre-wired with a 100' electrical cord, GFCI shock protector, and 220 Volt AC Switch.

2" shut off valves and quick-connect hose fittings shall be provided with the unit.

### **Warranty**

Two year limited warranty.



7100 Spectrum Lane ~ Missoula, Montana 59808  
800.791.8056 ~ 406.542.9781  
Fax: 406-542-1158  
[www.spectrumproducts.com](http://www.spectrumproducts.com)