

## ACCESS STEP SERIES MODEL - STANDARD LADDER

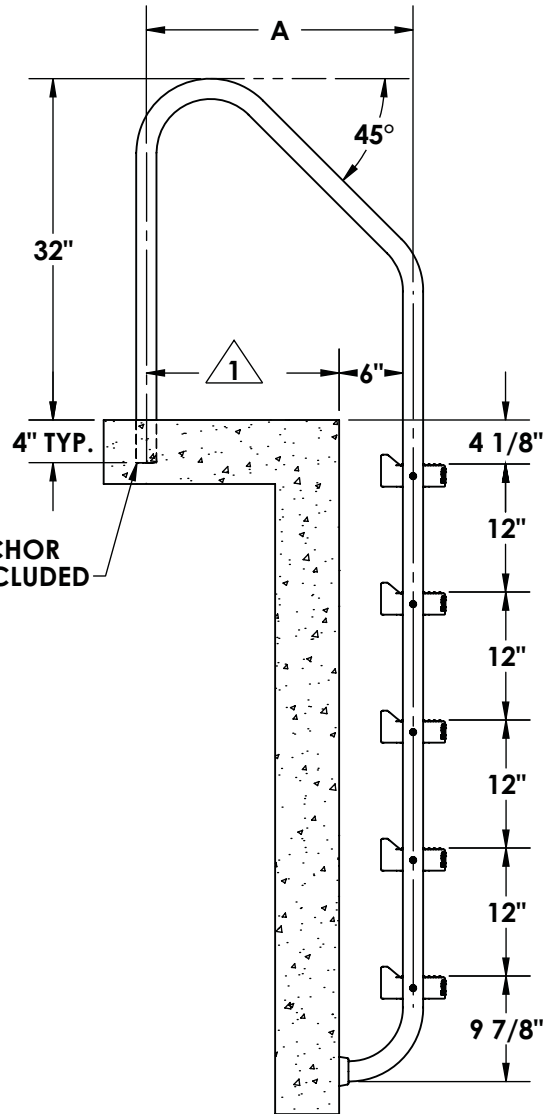
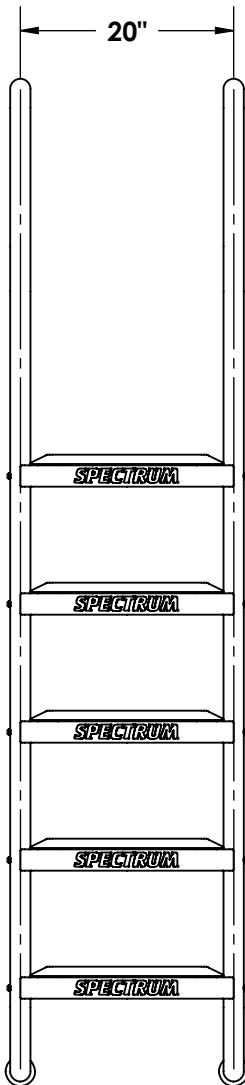
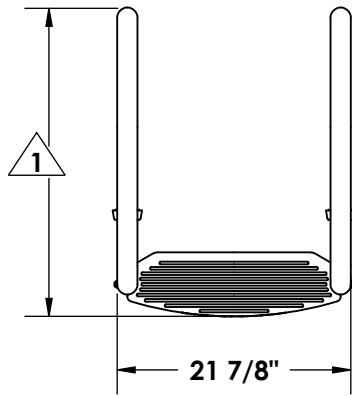

**NOTE:**

**1** DIMENSIONS VARY WITH SPECIFIC APPLICATIONS.  
SPECIFICATIONS ARE NOMINAL AND ARE SUBJECT TO CHANGE.  
PLEASE CONTACT SPECTUM PRODUCTS FOR CUSTOM APPLICATIONS.

A	X	STEP TREAD	X
25"		HDPE STEP TREAD (SHOWN)	
27"		STAINLESS STEEL STEP TREAD	
30"			
36"			



7100 Spectrum Lane  
Missoula, Montana 59808  
406.542.9781 \* 800.791.8056  
Fax: 406.542.1158  
www.spectrumproducts.com

### ENGINEERING DATA

PRODUCT:	STANDARD LADDER
PRODUCT #:	35135
REVISION:	A
MATERIAL:	300 SERIES STAINLESS STEEL

## **5 Step Standard Ladder, product number 35135**

### **Rails**

The ladder shall be fabricated of 1.90" O.D. or 1.50" O.D. x \_\_\_\_ (0.65", .109", .145", .083" or .120" wall thickness 300 series stainless steel. Provided with two (2) rubber bumpers.

### **Steps**

Five (5) treads shall be provided. They shall be 20" wide, have a non-slip top surface, and shall be made of 300 series stainless steel.

### **Anchors**

The ladder shall be supported by two (2) 4" bronze wedge anchors.

### **Escutcheons**

Two (2) escutcheons shall be provided. They shall be stainless steel and keyhole shape.

### **Warranty**

Two year limited warranty.



7100 Spectrum Lane ~ Missoula, Montana 59808  
800.791.8056 ~ 406.542.9781  
Fax: 406-542-1158  
[www.spectrumproducts.com](http://www.spectrumproducts.com)