

**GUARDIAN SERIES
MODEL - 6' STIMSON**

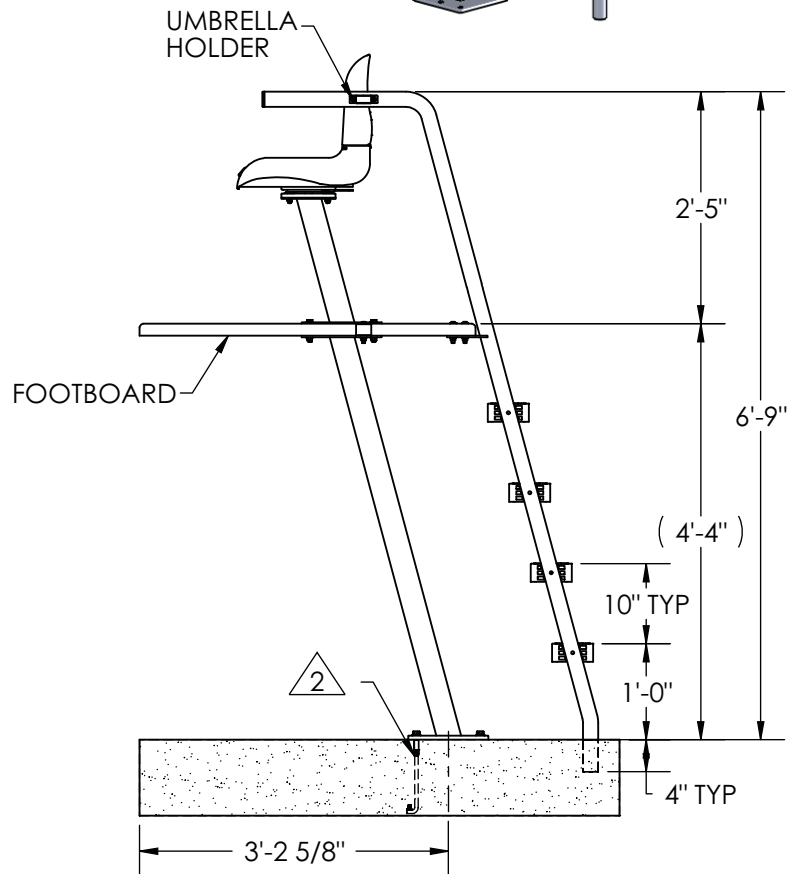
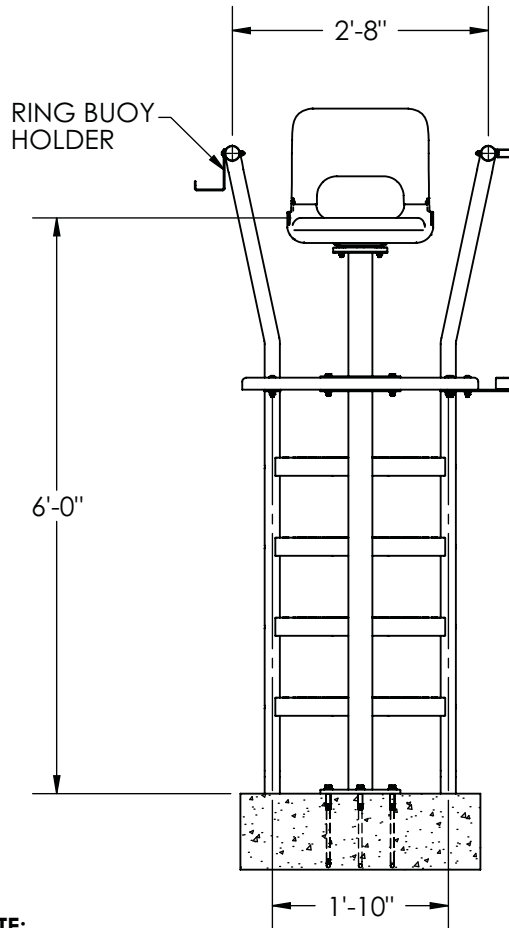
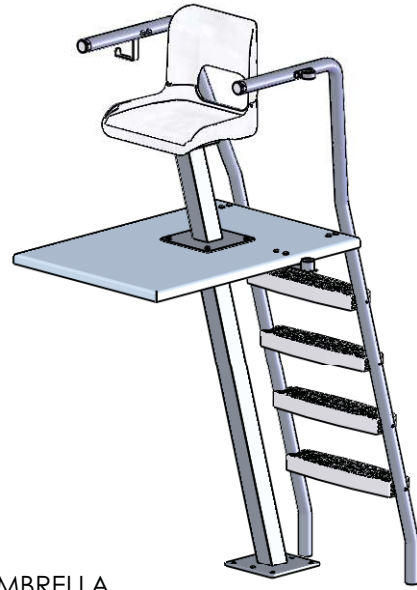

NOTE:

1 DIMENSIONS VARY WITH SPECIFIC APPLICATIONS.
SPECIFICATIONS ARE NOMINAL AND ARE SUBJECT TO CHANGE.
PLEASE CONTACT SPECTUM PRODUCTS FOR CUSTOM APPLICATIONS.

2 SAPPHIRE ANCHOR NOT INCLUDED - #20021-00



7100 Spectrum Lane
Missoula, Montana 59808
406.542.9781 * 800.791.8056
Fax: 406.542.1158
www.spectrumproducts.com

ENGINEERING DATA

| | |
|------------|----------------------------|
| PRODUCT: | 6' STIMSON |
| PRODUCT #: | 44116 |
| REVISION: | A |
| MATERIAL: | 304 SERIES STAINLESS STEEL |