

**GUARDIAN SERIES  
MODEL - OBSERVATION STATION**

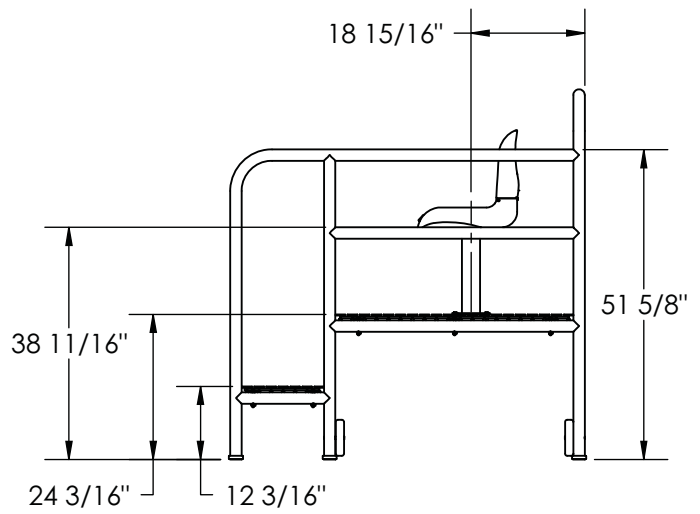
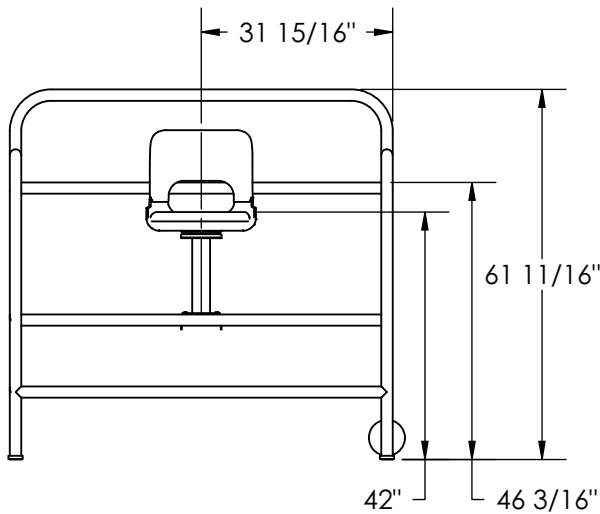
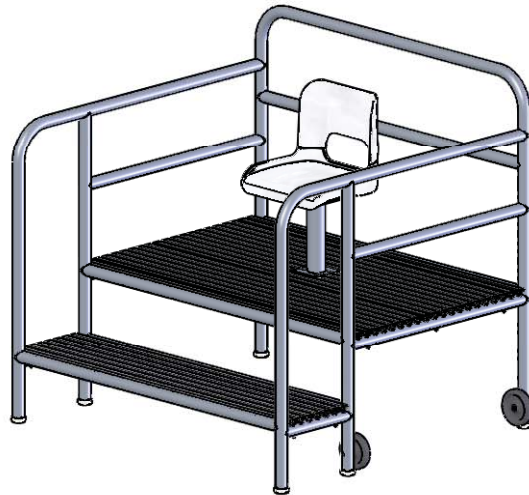
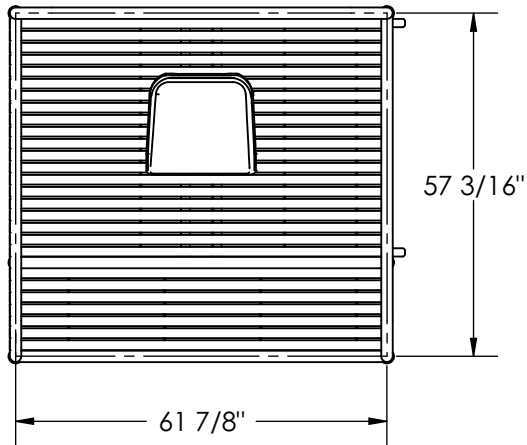

**NOTE:**

1 **DIMENSIONS VARY WITH SPECIFIC APPLICATIONS.  
SPECIFICATIONS ARE NOMINAL AND ARE SUBJECT TO CHANGE.  
PLEASE CONTACT SPECTUM PRODUCTS FOR CUSTOM APPLICATIONS.**

**SPECTRUM**  
Products

7100 Spectrum Lane  
Missoula, Montana 59808  
406.542.9781 \* 800.791.8056  
Fax: 406.542.1158  
www.spectrumproducts.com

**ENGINEERING DATA**

PRODUCT:	OBSERVATION STATION
PRODUCT #:	40923
REVISION:	A
MATERIAL:	304 SERIES STAINLESS STEEL