

THERMAL-KING® SERIES MODEL - BITTERROOT TRIPLE

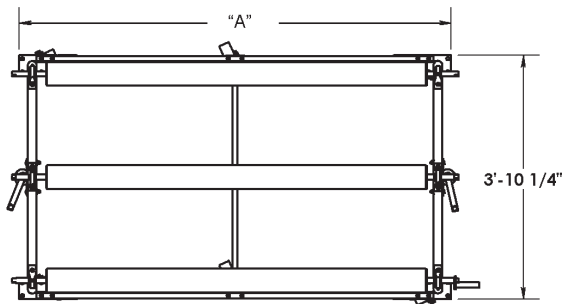

Model	Size	Dimension "A" (inches) "B"	
		"A"	"B"
50180	15-foot	214.125	192
	18-foot	250.125	228
	20-foot	274.125	252

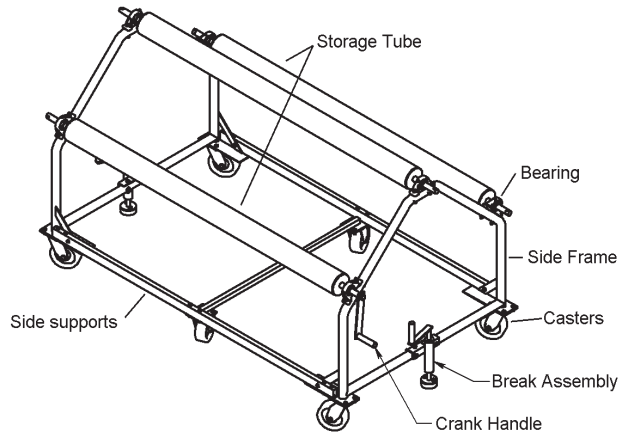
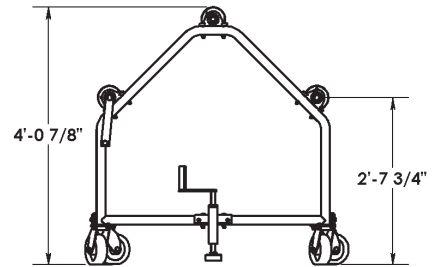
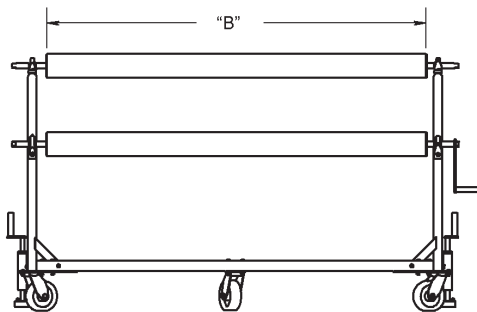

- APPROVED
- REVISE AND RESUBMIT
- APPROVED AS CORRECTED
- REJECTED
- SUBMIT SPECIFIED ITEM

Approval is only for conformance with the design concept of the Project and compliance with the information given in the Contract Documents. Contractor is responsible for dimensions to be confirmed and correlated at the job site for information that pertains solely to the fabrication process or to techniques of construction, and for coordination of the work of all trades.

Signature _____ Date _____

**Note: Drawings not to scale. Specifications are nominal and are subject to change.*



7100 Spectrum Lane
Missoula, Montana 59808
406.542.9781 • 800.791.8056
Fax: 406.542.1158
www.spectrumproducts.com

ENGINEERING DATA

Product:	Thermal-King™ Series - Bitterroot Triple
Product #:	50180
Date:	11/2006
Data Sheet #:	SA 50160.1106

Thermal-King Series, Bitterroot Triple Reel, Models 50180 – up to 20' wide

The blanket storage reel system assembly shall be portable, and consist of two side frames, side supports, three storage tubes, tube crank handle, transport casters and a braking system. It shall have a minimum storage capacity of 492-linear feet or 9,840 square feet of energy saving blankets.

Side Frames

The reel assembly shall have two (2) side frames. Each fabricated from square tubing 2.00" x 0.120" wall thickness, type 304 stainless steel polished to a 400 grit finish.

Side Supports

The side frames shall be connected by two- (2) 2" x 1" x 0.065" wall thickness square tube supports. Side supports shall be fabricated of type 304 stainless steel polished to a 400 grit finish.

Storage Tubes

The blanket storage reel system shall facilitate three (3) storage tubes. The tubes shall be fabricated of 4.50" x 0.120" wall, 304 stainless steel. The tubes shall be up to 20' long and shall be connected to each side frame by way of nickel-plated pillow block bearings. The blanket storage reel assembly shall be supplied with one 304 Stainless steel crank handle.

Casters

Stainless steel casters shall be provided with the blanket storage reel assembly. Six- (6) casters shall be provided. Each caster shall employ six- (6) inch diameter cast polyethylene wheels. The casters and wheels will be design to support a minimum of 1,600 pounds.

Brake Assembly

Two- (2) foot operated brake assemblies shall be provided with the blanket storage reel system. The brake shall be fabricated of 304 Stainless steel. Brake pads will be 2- (3.5) inch diameter made of non marring vulcanized rubber. The brake shall be supplied with a brake setting/release foot pedal.

Storage Reel and Blanket Cover

A storage reel blanket cover is an available option. The cover shall be fabricated of twelve by twelve woven polyethylene fabric that is to be double coated with an ultraviolet inhibiting film. The cover shall protect the blanket assemblies for premature wear and ultraviolet degradation.

Warranty

Two year limited warranty.



7100 Spectrum Lane ~ Missoula, Montana 59808
800.791.8056 ~ 406.542.9781
Fax: 406-542-1158
www.spectrumproducts.com